

Ecoboiler Cassette Stove Installation Guide



Ecoboiler Cassette

**AFTER INSTALLATION RETAIN THIS GUIDE & PASS
TO CUSTOMER FOR FUTURE REFERENCE**

EN 13229:2001 +A1:2003 +A:2004 CE

BK680 SPECIFIC Rev 02

OCT 2016 

Stratford Ecoboiler Cassette Stove Installation Guide

Arada Ltd

October 2016

Please carefully read through the entirety of this installation guide before commencing installation. Should you have any questions about our stoves that are not covered in this manual, please contact the Arada retailer in your area, or call our technical support department on 44 (0)1297 35998. You should retain these instructions for future reference.

Arada has a policy of continuous product development and therefore we reserve the right to amend specifications without prior notice. Due to printing cycles, items or options may be described before they are generally available or after they have ceased. Please check with your retailer or dealer if you are unsure about any aspect of your stove, its installation or correct use.



Any further warnings in this document will be marked out in a box such as this one. Ignoring the warnings could lead to damage/injury to persons and/or property.

Contents

1 Warnings	4
2 Health & Safety	5
3 Installation Requirements	
3.1 Hearths & recesses.....	5
3.2 Combustible materials.....	6
3.3 Combustion air requirements.....	7-8
4 Flues And Chimneys	9-10
5 Installing the stove	
5.1 Removing the door	11
5.2 Removing the fuel retainer	11
5.3 Removing the throat plate	11
5.4 Assembling the grate bars	11-12
5.5 Connecting the spigot outlet to flue system	12-13
5.6 Combustion air connection.....	13
5.7 Sealing the back and base of inset stove to fire surround	14
5.8 Fitting the surround trim	14
6 Connecting the boiler to your heating circuit	
6.1 Integral boiler	14
6.2 Water connections	15
6.3 Safety vent circuit	15-16
7 Maintenance	
7.1 Removal of ash around the damper and thermostat.....	17
7.2 Removal of the thermostat	18-19
7.3 Calibration / setting the thermostat assembly	20
8 Final check list and commissioning the stove	21
9 Reference	22-23

1 Warnings

It is a LEGAL REQUIREMENT that the installation of all new or replacement, wood or solid fuel heating appliance, obtain building control approval from your local authority or the installation work must be carried out through a government approved competent persons scheme. A list of all competent person schemes can be found : <https://www.gov.uk/guidance/competent-person-scheme-current-schemes-and-how-schemes-are-authorized>

Any manufacturer's instructions must not be taken as overriding statutory requirements.

The Ecoboiler Cassette MUST NOT be connected to a shared flue system.

Please Note: Classification of these appliances is for intermittent use only.

Do not use aerosol sprays or any other flammable materials near the appliance when in use.

Do not use the appliance as an incinerator.

Use only recommended fuels, STRICTLY NO unsuitable and non recommended fuels or materials or liquid fuels allowed.

Pure petroleum coke or Bituminous house coal must NOT be burned in this appliance. The use of these fuels will invalidate the appliance guarantee.

Arada recommends the use of approved smokeless fuels which have been deemed suitable for use on closed appliances. If in doubt, contact The Solid Fuel Association, telephone: 0845 601 4406 / 01773 835400 or visit [ww.solidfuel.co.uk](http://www.solidfuel.co.uk).

Please ensure that the air inlet vent grills to the dwelling are not obstructed or liable to be blocked.

Caution must be exercised during operation of the appliance as both internal and external surfaces will be hot to touch, use the stove mitten provided when the appliance is in operation.

A fireguard conforming to BS 8423:2002 should be used in the presence of children or elderly people.

Always observe the distances to combustible materials as stated on the appliance data plate and in the technical data section of this manual. Ensure no soft furnishings or combustible materials are susceptible to heat radiating from the appliance.

2 Health and Safety

Before any installation work is undertaken consideration must be given to the Health and Safety at Work Act 1974. Safe working practices should be followed at all times.

Please consult health and safety guidelines for advice on handling heavy and/or large items.

During installation ensure that adequate precautions are taken to avoid unnecessary risk to yourself or any householder.

The danger from the caustic nature of fire cement, should be avoided by using these accepted methods: Wear gloves when handling fire cement. Wear goggles when chiselling or looking up chimneys.

This stove contains no asbestos. If there is a possibility of disturbing any asbestos in the course of the installation then please seek specialist guidance and use appropriate protective equipment.

3 Installation Requirements

3.1 Hearths and recesses

The stove should be installed on a surface with adequate load bearing capacity. If the existing construction does not meet this prerequisite, suitable measures (e.g. load distributing plate) should be taken to achieve it. Please pay particular attention when examining existing building work for suitability to meet the following requirements.

Hearths and recesses for Cassette stoves should have a sufficiently flat surface to allow a good seal to the stove body to be created during its installation. Stonework, uneven bricks etc. may need further work to ensure that this can be achieved.

Cassette stoves should be installed into a recess on a non-combustible surface not less than 125mm thick (conforming to Building Regulations) of suitable load bearing capacity.

Allowances should be made for the expansion and contraction of materials which are fitted up to and near the appliance.

Dimensions of the constructional hearth for all stoves (including any 'hole in the wall' type installation) should project at least 500mm forward of the front of the appliance and 150mm at the sides. The surface of the hearth should be free of combustible materials. The superimposed hearth for all installations should project at least 225mm forward from the front of the appliance and 150mm either side of the edge of the appliance.

In most buildings with solid concrete or stone floors, the requirement will be met by the floor itself, but mark the hearth to ensure floor coverings are kept well away or use different levels to mark the hearth perimeter.

Please be aware that hot air can cause staining above the fire in a similar fashion to walls above radiators. To help prevent this and cracking we recommend that plastering above the fire should be fitted with reinforcing expanding mesh for at least 220mm above, and the full width of the fire. You should also use a suitably heat resistant plaster.

When installing the stove into a recess it is important that the front outer jacket edges sit 5mm proud of the wall surface to enable the trim to clip onto the fire.

3.2 Combustible materials

Please view the product sheet which accompanied your stove for specific minimum distances to combustible measurements.

Ideally, adjacent walls should be of suitable non-combustible construction, preferably brickwork.

In large fireplaces take care that any supporting beam is protected by a 13 mm sheet of heat resistant fire board spaced 12mm off the surface with strips of non-combustible material.

Make sure that there is a gap between an un-insulated flue system and any combustible material. This gap must be at least 3X the outside diameter of the flue pipe, or 1.5X the flue diameter to non combustible surfaces. Please consult the flue manufacturers specification for insulated flues.

3.3 Combustion air requirements

All stoves require ventilation to burn safely and correctly.

The Stratford Ecoboiler Cassette differs from conventional stoves in that air for combustion is only supplied from an external source rather than the room or dwelling.

The fitting of the external air allows the stove to be installed in a room that may otherwise be sealed to an extent that would prohibit the correct and safe burning of the stove. This may also apply to houses in general sealed to a very high level to meet various energy efficiency targets.

Therefore the requirements normally associated when installing a stove, for example, allowing for the permeability of the house (air permeability is the general seepage of air into the house via air vents, doors and windows etc.) are not applicable.

The product is factory fitted with a with an air supply adaptor located on the base of the appliance that will accept a flexible pipe of a diameter 102mm externally. See Fig. 1 & 4 for details.

The air duct fitted must be of minimum diameter 100mm, non combustible and ducted to the outside in a manner that will not effect the performance of the stove.

No sharp bends and a maximum duct length of 10 metres is permissible.

Where the duct terminates on an external wall ensure that there is no risk of blockage with leaves or accidental placement of items, ensure there is no risk of ingress of moisture or access for rodents.

Avoid fitting the air inlet pipe through a wall that may be unduly effected by prevailing winds that may cause a suction on the pipe bringing combustion products back down the flue.

In extreme cases the placement of the terminal on the external wall may pose problems and remedial action may be required to relocate the terminal or provide two terminals on opposite walls to balance the wind effect.

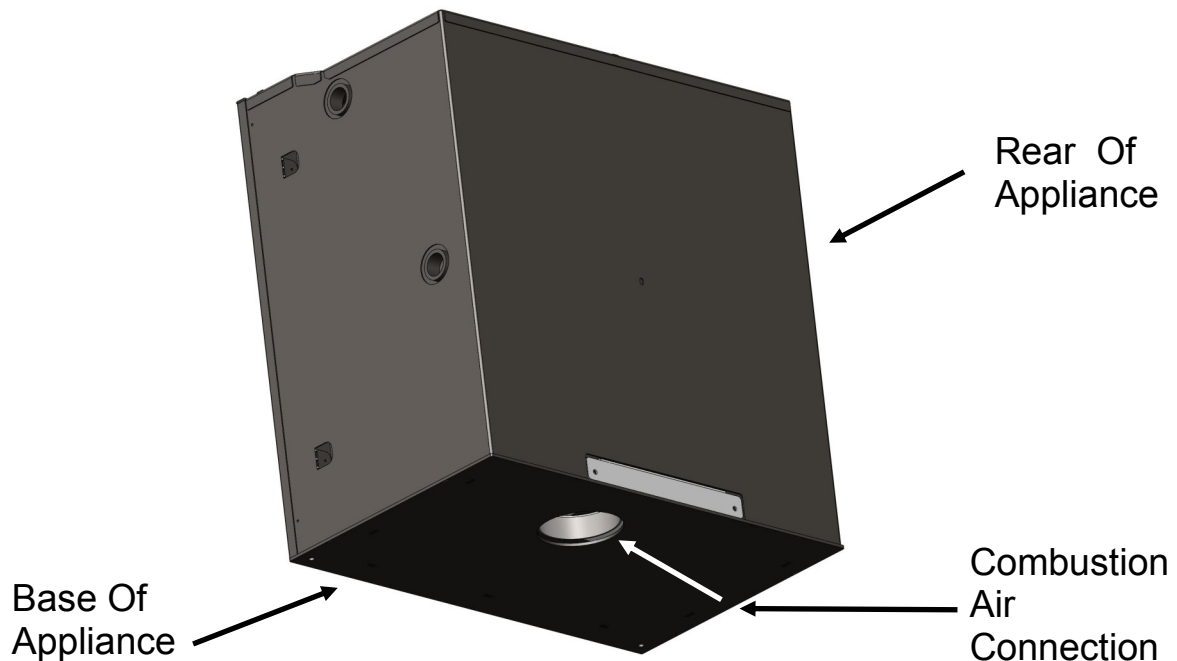

FIG. 1. Direct Air Connection (Combustion Air)

Where the stove is connected to outside air and there is **NO** draught stabiliser is fitted, there is no requirement for an additional air vent, provided a successful 'smoke draw test' has been carried out as part of commissioning.

NOTE: If a requirement of the installation, a draught stabiliser **IS** fitted, then a permanent air vent will be required and should be increased by 300mm² for each KW of rated output up to 5KW and an additional 850mm² for each KW output over 5KW. Please refer to Building Regulations Part J (BS 8303 Part 1).

For further information on detailed guidelines on required ventilation sizes please refer to the Document J or your local building control department.



The fitting of an extractor fan in the same room as the stove, or an adjacent room is not permitted. A spillage test will be required to determine how any extractor fans may affect the required size of ventilation requirements.

4 Flue and Chimneys

The stove must be connected to a suitable and efficient flue so that products of combustion (fumes) from the stove are expelled to the outside air. Please remember that chimney draught is dependent on four main factors :

- Flue gas temperature
- Flue height
- Flue size
- Flue terminal

To ensure a good up draught it is important that the flue gases are kept warm and that the flue size suits the stove. The termination of the outlet at the top of the flue also needs to comply with Building Regulations.

The minimum effective height of the flue must be at least 4.5 metres from the top of the stove to the top of the flue outlet. When warm the flue draught should be between 0.1 to 0.2 mbar.

The draw of a chimney / flue can vary in different weather conditions and the customer should be made aware of this.

Failure to correct an over-drawing flue will invalidate the warranty.

A chimney may comply with regulations but could still be subject to down draught and similar problems. A chimney terminating above the ridge level is generally less likely to suffer such problems.

If a new chimney is being provided it should fully comply with the relevant Building Regulations that specify the requirements for solid fuel burning installations. Suitable types of chimney include the following :

- Masonry Chimney : Built with clay or concrete liners, or a chimney block system meeting Building Regulations. These types of chimneys should be installed in accordance with the Building Regulations and BS EN 15287-1:2007.
- Factory Made Insulated Chimney : Complying with BS 4543:Part 2 (often called Class 1 prefabricated metal chimney). These types of chimneys should be installed in accordance with Building Regulations and BS EN 15287-1:2007.

Due to the gradual introduction of European Chimney Standards chimneys will be specified according to their performance designation as defined in BS EN 1443 that covers the General Requirements for chimneys. The minimum performance designation required for use with solid fuel burning stoves is T450 N2 S D3.

The flue and chimney installation must be carefully checked by a competent person before fitting the stove to ensure it is suitable and will work safely.

If the chimney is old (i.e: built of brick or stone without a liner) or being opened up for reuse additional checks and smoke testing as described in Appendix E of the Approved Document J 2010 Edition should also be carried out to ensure the flue and chimney are in good operating condition.

Check the existing flue is in good condition with suitable access for collection and removal of debris.

It is also important that suitable flue pipe (recommended at least 600mm in length) complying with the Building Regulations is used to connect the stove to the flue in the chimney. Suitable access should be provided into the flue for regular inspection and sweeping of the flue ways.

The installer should comply with Building Regulations requirements in respect of providing a Notice Plate giving details on the chimney, flue lining, hearth and fireplace installation.

Chimneys should be as straight as possible. Horizontal runs should be avoided except where the rear outlet of the appliance is used, in which case the horizontal section should not exceed 150mm in length. If necessary a combination of 45° and 90° bends can be used as long as the sum of their angles is not greater than 180° in total. IE : Four 45° bends, or two 45° and a 90° bend.

If the stove appears to be working hard but produces very little output to the room it is likely that excess draw is present in the chimney, and that heat is being sucked out of the appliance and up the chimney. If this is the case we recommend the fitting of a draught stabiliser in preference to a flue damper, in the interest of safety and efficiency.

5 Installing the Stove

To make the stove easier to manoeuvre (thus safer) we recommend you remove the following parts which can then be refitted when the stove is in its final position:

- Door (To help prevent the glass from breaking)
- Fuel Retainer
- Throat Plate
- Grate Bars
- Operating Tool
- Ash pan

5.1 Removing the door.

Open the door so that it's perpendicular to the stove body and then carefully lift the stove door upwards of its hinges. To replace the door reverse the instructions above.

5.2 Removing the fuel retainer

The fuel retainer can simply be removed by lifting the piece upwards and withdrawing the location lugs from the location slots within the front brace. The piece can be rotated through the door aperture. Reverse procedure for re-fitting.

5.3 Removing the throat plate

The throat plate rests on a structural brace welded to the rear face of the appliance. Within the brace there are two location slots, these align with the two lugs protruding from the throat plate.

Lift the throat plate and with the location lugs clear from the brace, rotate the throat plate and withdraw from the appliance. Reverse procedure for refitting.

5.4 Assembling the grate bars

In your stove the grate system comprises of a series of cast iron grate bars, seated on a pair of combs. All bars in the grate are identical.

The bars should be seated with every other bar rotated 180 degrees, so the ends marked 'H' and 'L' alternate on each comb. When assembling the grate,

fit bars to the low sections of the comb first by seating the ends marked 'L' onto the low part of the comb, whilst the ends marked 'H' should then be seated on the high sections. (See Fig. 2, below)

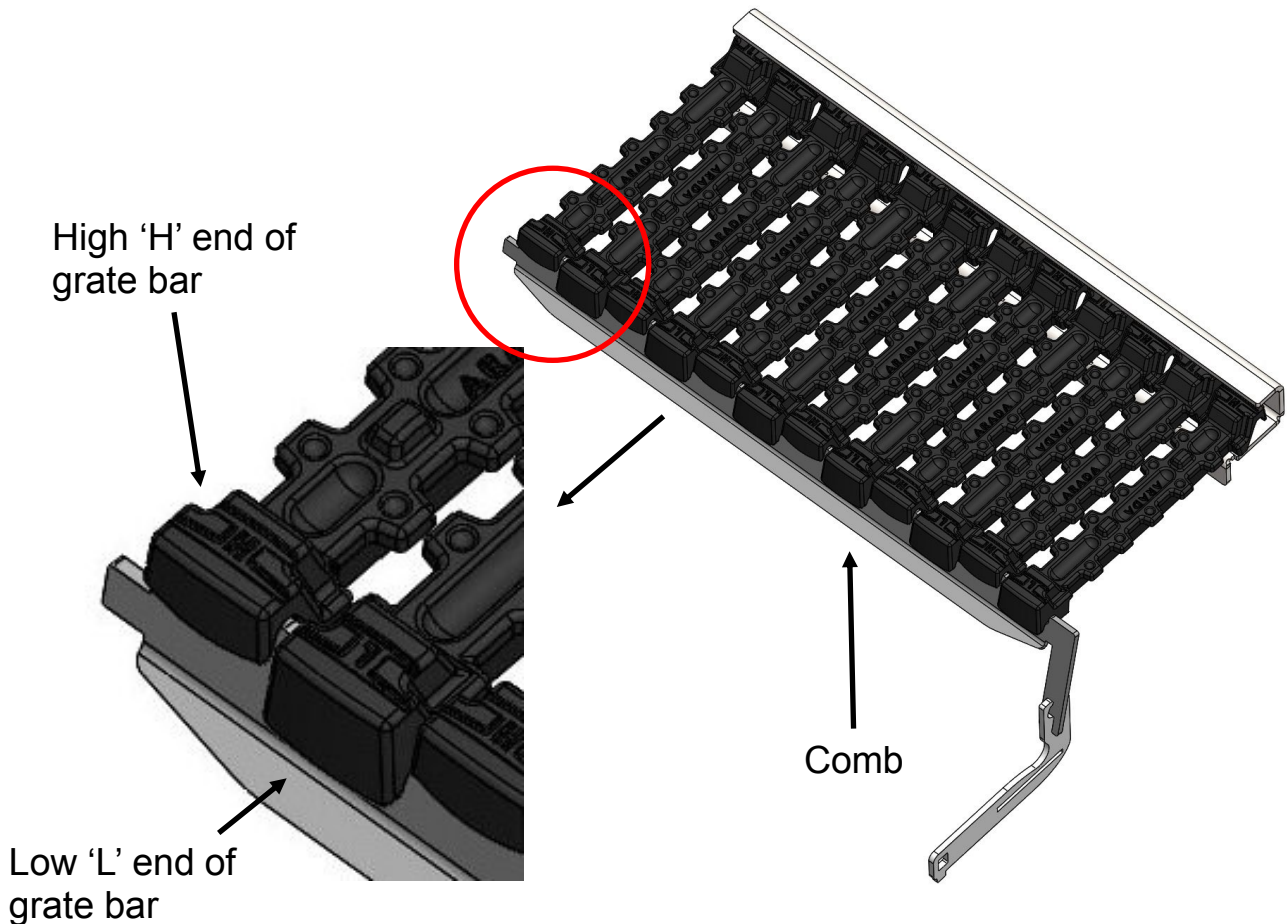

FIG. 2. Assembled Grate Bars Shown Seated On Comb

5.5 Connecting the spigot outlet to the flue system

The flue pipe must be fitted inside the outlet spigot as shown in Fig. 3 adjacent page. Failure to do so, could result in the spillage of condensation running down the flue and ultimately into the firebox of the appliance.

Fire cement and glass fibre rope seal should be used to create an airtight seal between the flue and spigot. See Fig. 3. for information.

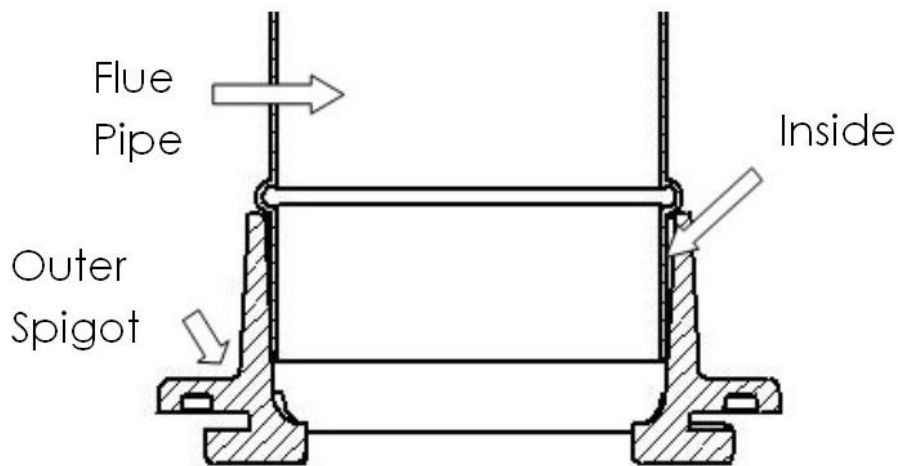

FIG. 3. Fitting the flue pipe inside spigot collar

5.6 Combustion air connection

As described earlier in this manual, the connection for the combustion supply air is on the base of the appliance. The connection hole is offset from the middle of the appliance, please see the below plan diagram

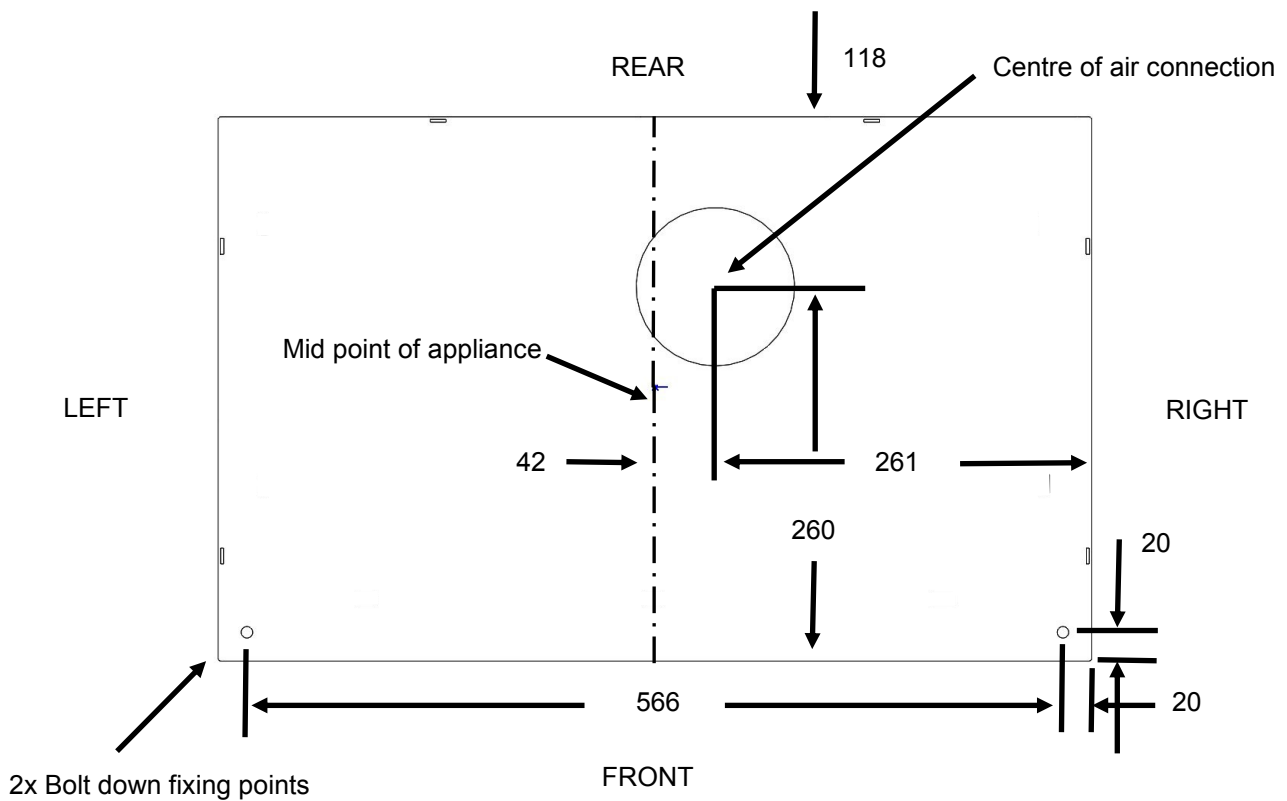

FIG. 4. Plan view of appliance—Showing air connection & fixing

5.7 Sealing the back and base of inset stoves to a fire surround

In order for the stove to operate correctly and at maximum efficiency it is necessary to achieve a good seal between the back face of the stove convector (rear body section), the stove back base sections and the decorative fire surround and hearth.

This should be achieved using fire cement. Any void surrounding an inset stove when installed should be filled with fire cement or fire cement / vermiculite mix in the interest of safety and efficiency.

5.8 Fitting the surround trim

Please refer to the instructions supplied with the decorative trim, for information on how to fit them.

6. Connecting the boiler to your heating circuit

6.1 Integral Boilers

Integral boilers should only be connected with the flow and return connections of any circuit on opposite sides of the appliance (cross -flowed) and to an indirect hot water tank / system with Fernox or other similar corrosion inhibitor to prevent both corrosion and the formation of lime scale.



All Arada boiler stoves must be installed in an indirect vented (also known as an open vented) central heating system.

Connecting pipes should be screwed to a maximum depth of 19mm for the face of the tapping boss (1" BSP Parallel).

Remember to incorporate a drainage plug / tap at the lowest point of the circuit to facilitate draining & flushing.

If a pipe stat is not fitted to control the radiator circulation pump, then cold water corrosion may occur.

6.2 Water connections

To connect the indirect hot water cylinder to the stove, use 28mm copper pipes. Ensure that the pipes rise continuously to the cylinder.

Ensure that runs are not too long (i.e. 6 metre maximum each for flow and return). Install the cylinder above the level of the appliance and as close to it as possible. Within reason the higher the cylinder the faster the circulation. Ensure no valves are present in the pipes.

In addition to providing hot water the primary circuit is essential in providing a 'heat leak' radiator to absorb excessive heat produced in the event of a circulating pump shutting down.

Heat is produced in varying quantities while the stove is alight and care must be taken to ensure that effective circulation can occur around the primary circuit to carry the heat away thus preventing boiling. The heat output of any radiator installed as a 'heat leak' should not be less than 10 percent of the rated output of the appliance to which it is connected. It should not be fitted with a control valve as it should never be turned off or down. The hot water cylinder must be indirect with a minimum capacity of 110 litres conforming to BS 1566 part 1.

A radiator of approximately 2m² surface area should be connected to the primary circuit.

6.3 Safety Vent Circuit

This circuit (shown in Fig. 5 on the next page) consists of a cold feed pipe, a separate expansion pipe and expansion tank. The possibility that water in the stove boiler may boil can never be completely ruled out, and it is therefore vital to ensure that cold water can be provided to the boiler and steam vented from it at all times.

The use of an expansion tank is important. This should have a capacity of at least 7 percent of the systems total water capacity. The cold water feed pipe should be at least 22mm in diameter.

There must not be any shut-off valves in the circuit. Pipes should be run so as to avoid air locks. A safety valve should be fitted into the expansion pipe close to the boiler. The expansion pipe should not be branched off from the cold water feed pipe to ensure that it cannot be blocked by any sediment matter originating from the expansion tank.

It is often possible and good practice to utilise the primary flow and return as part of the safety circuit.

The ball valve and over-ow pipe (28mm diameter) from the expansion tank should be copper. All pipes in unheated spaces should be lagged.

Various examples can be seen on page 22 & 23.

With solid fuel appliances, it is not practical to provide a sufficiently rapid reaction for shutting down the fuel in the event of a sudden rise in water temperature. A temperature valve, or preferably, a combined temperature and pressure relief valve should be installed to operate in the event of high water temperature occurring.

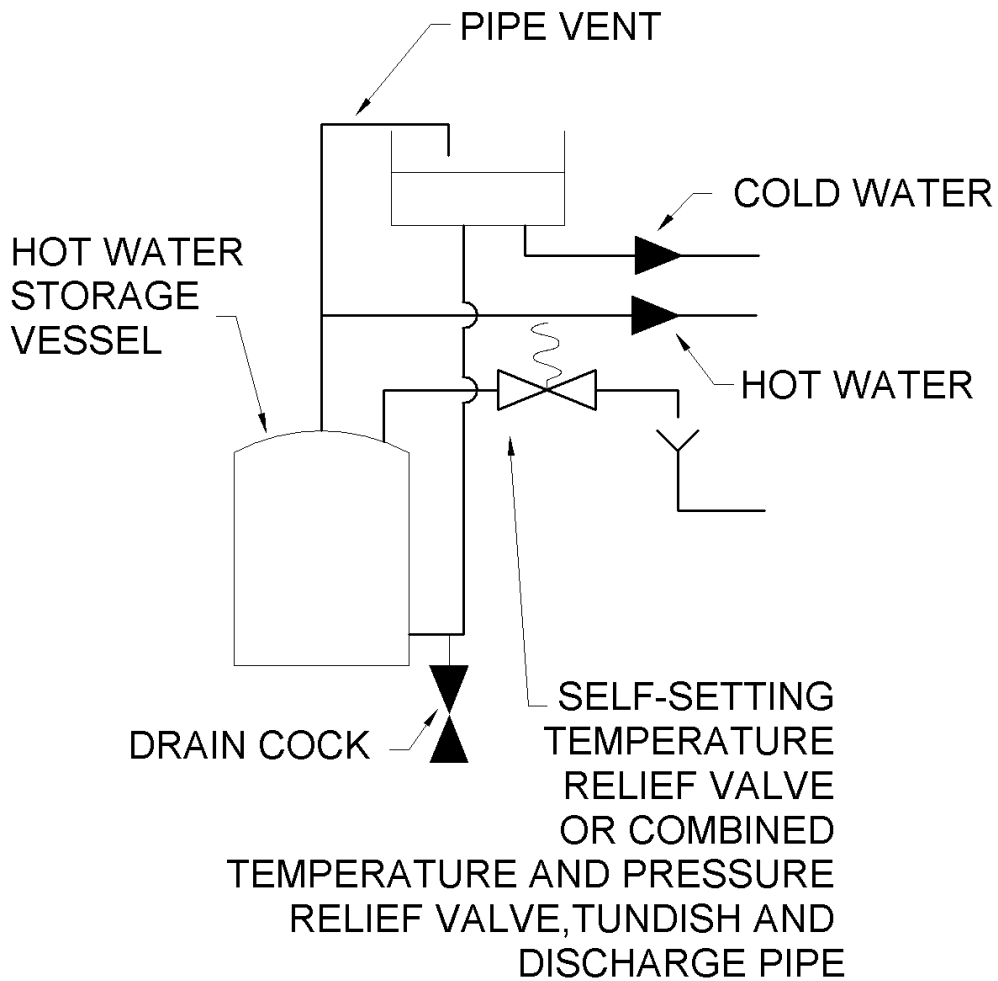

FIG. 5. Safety Vent Circuit

7 Maintenance

7.1 Removal of ash around the damper and thermostat

Regular checking and removal of ash from around the damper flap area, which is central to the inner rear of the firebox cavity will ensure correct operation and performance from your appliance.

To remove ash from around damper flap intake:

- Make sure the stove is unlit and cold.
- Open the main fire door.
- Remove the fuel retainer, ash pan and grate bars.
- Remove the ash pan heat shield, by using the finger cut out at the front of the part, with draw part through the ash pan opening. See Fig. 6.
- Vacuum away any loose material & ash from the bottom rear of the firebox (shown below in RED colour)(Fig. 7.).
- Reverse above procedure for re-fitting.

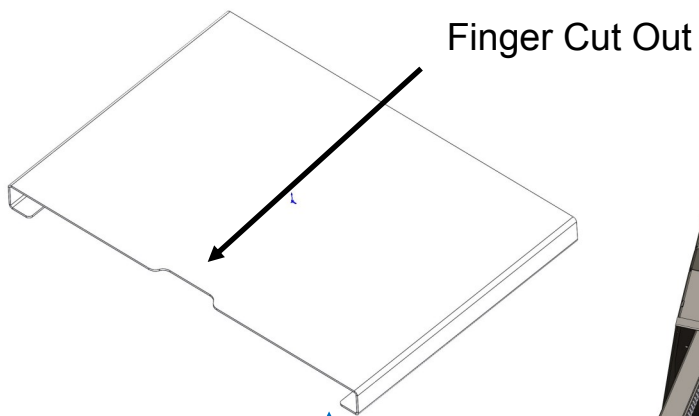

FIG. 6. Ash Pan Heat Shield

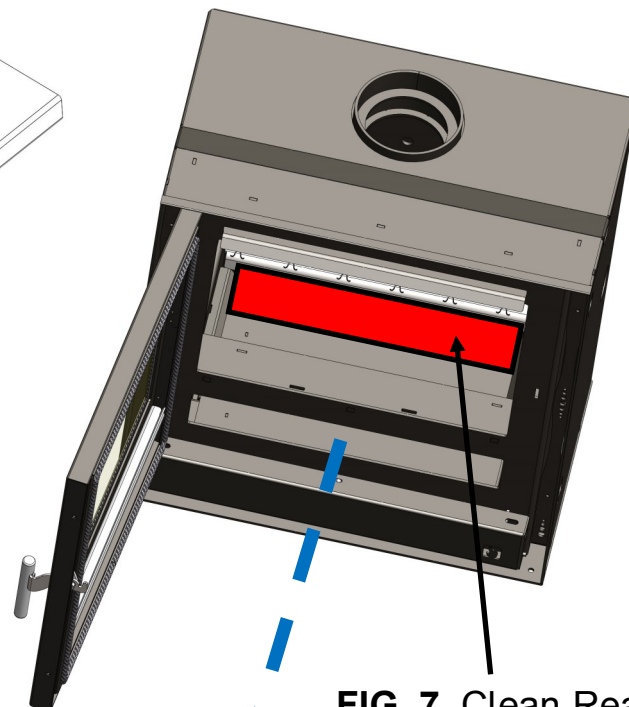

FIG. 7. Clean Rear Firebox Area— Shown In RED

7.2 Removal of the thermostat

The thermostat and damper flap have been factory set during manufacture. However, over a period of time, it may be necessary to calibrate or check the setting of the thermostat assembly.

Follow the steps on removal of ash from damper & thermostat, then -

- Open the control door and locate the two dome headed screws. Using a 3mm hex key, remove these fixings and retain for re-fitting (FIG. 7).
- Remove the thermostat knob, by releasing the grub screw by using a 2mm hex key (NOTE: DO NOT REMOVE SCREW). Pull on the knob and remove from the shaft.
- From inside the firebox push the air box towards to rear of the appliance, this will disengage the retaining brackets, you will then be able to lift the front (you may need to rotate the air control lever to clear the slot within the stove body). With draw the air box at approx. 45 degrees through the door aperture.
- Once the air box has been removed, this will expose the thermostat fixings (2 no.), remove using a 8mm spanner or socket (FIG. 8.)
- On the right of the thermostat assembly towards the front of the stove, remove the sensor wire cover plate again using an 8mm spanner, for the 2 no. screws (FIG. 8).
- Outside of the firebox, RIGHT hand side of the stove, remove the 2 no. fixings that hold the outer side spacer trim, using a Pozi screwdriver. (FIG. 8.)
- Removing this trim will reveal the sensor phile, located close to the top boiler connection terminal. Remove the sensor from the location tube and carefully thread the sensor and connection wire through the corner of the body. NOTE : TAKE CARE NOT TO KINK SENSOR WIRE. (FIG. 10.)
- The thermostat and damper assembly can now be removed.

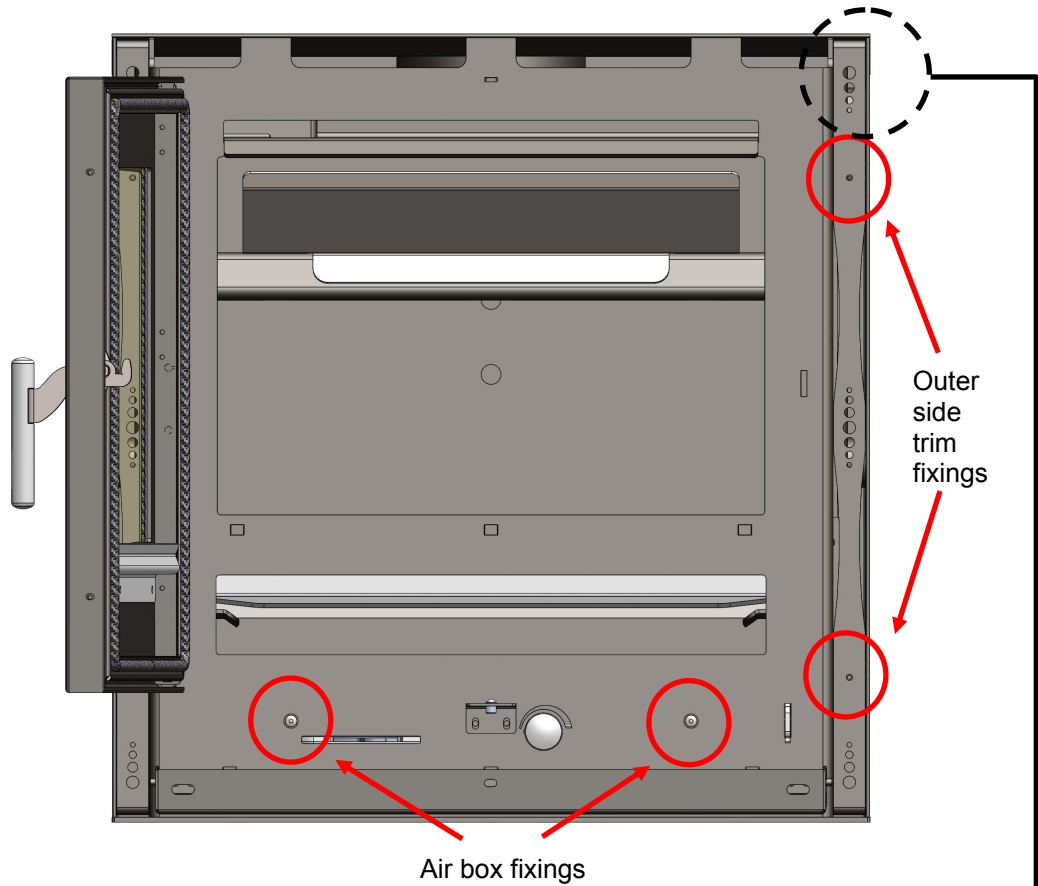

FIG. 8. Fixing locations (External With Door Open)

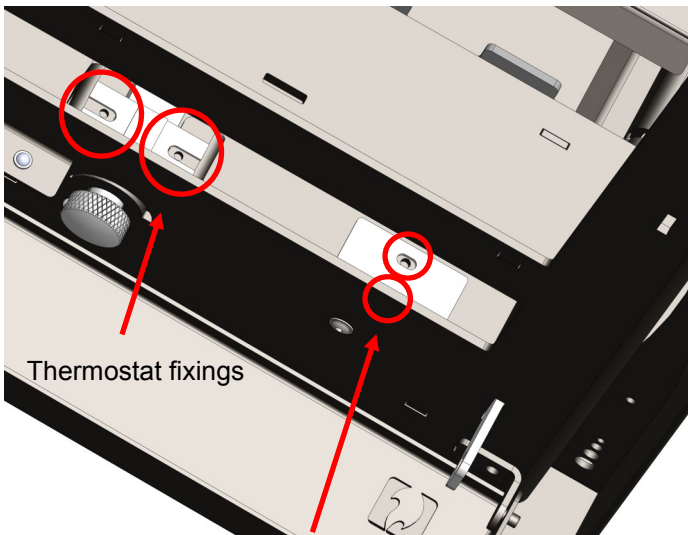

FIG. 9. Fixing locations (Internal)



FIG. 10. Thermostat sensor location (Behind outer side spacer trim)

7.3 Calibration / Setting The Thermostat Assembly

With the thermostat assembly removed, calibration / setting procedure can be done in the following way -

- Replace the thermostat control knob (previously removed, during thermostat removal from stove).
- Rotate the control knob fully clockwise until it reaches the stop position.
- Place the thermostat on a flat surface with a base of the mechanism body on a small piece of 8mm MDF or similar wood.
- Now measure the high end of the damper flap / plate between the bench and the top edge of the damper plate (the edge furthest from the control knob) See FIG. 11.. This measurement should be 29mm +/- 1mm, if not adjust as follows -
- Slacken off the locking nut against the damper either in or out as required.
- Check the distance at the high end of the damper plate again.
- Once set correctly re-lock the locking nut.
- Check distance is still correct.
- Once the correct distance is achieved please refit the thermostat assembly by following the reverse procedure '**7.2 Removal of the thermostat**'.



FIG. 11. Damper Flap Check

8. Final check list and commissioning the stove

Before handing over the installation to the customer it is a requirement under Document J (of the Building Regulations for England & Wales) that the appliance is lit and the functioning of the chimney system is checked for satisfactory operation. The functioning of the hot water and heating system should be fully checked.

Please record the checks in the table below :

Operate the heating system and set the pump head.	
Balance the radiators.	
Re-vent and ensure there are no air leaks.	
Check all joints & seals.	
Clean the outside of the appliance to prevent any stains from becoming burnt on.	
Check the flue draught which should read 1 –2 mm or 0.1—0.2 mbar.	
For a registered competent persons scheme please complete a Certificate Of Compliance, which is used for checking and reporting the installation as imposed by the Government.	
Explain the controls and operation of the appliance to the customer.	
Ensure a Carbon Monoxide alarm is fitted. This must be between 1 to 3 metres of the appliance and approximately 150mm below the ceiling level.	
A fireguard conforming to BS 8423:2002 should be used in the presence of children and old or infirm people.	
Explain to the customer, that when lighting a boiler stove, condensation may form on cold parts of the stove and drip off of it during ignition. This is normal and not an indication of a leak.	

9. Reference

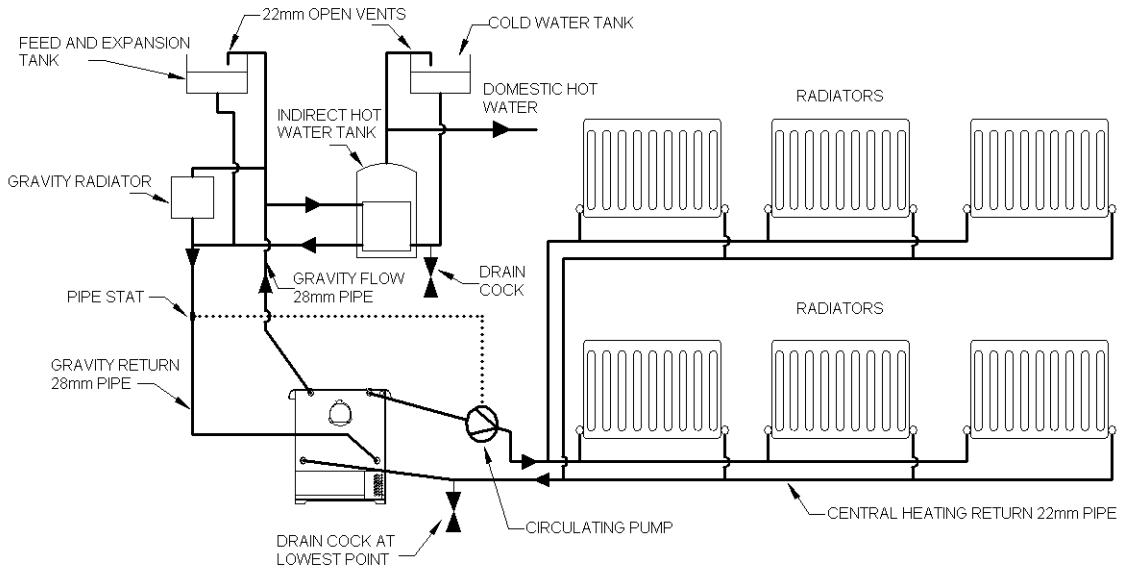

FIG. 12. Central heating and domestic hot water system using four boiler tapplings.

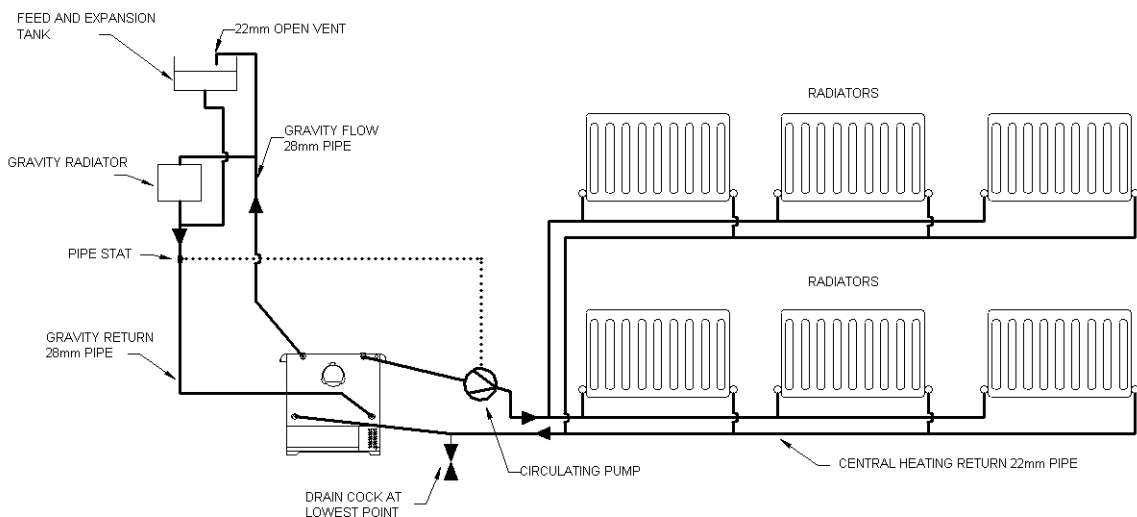

FIG. 13. Central heating without domestic hot water system using four boiler tapplings.

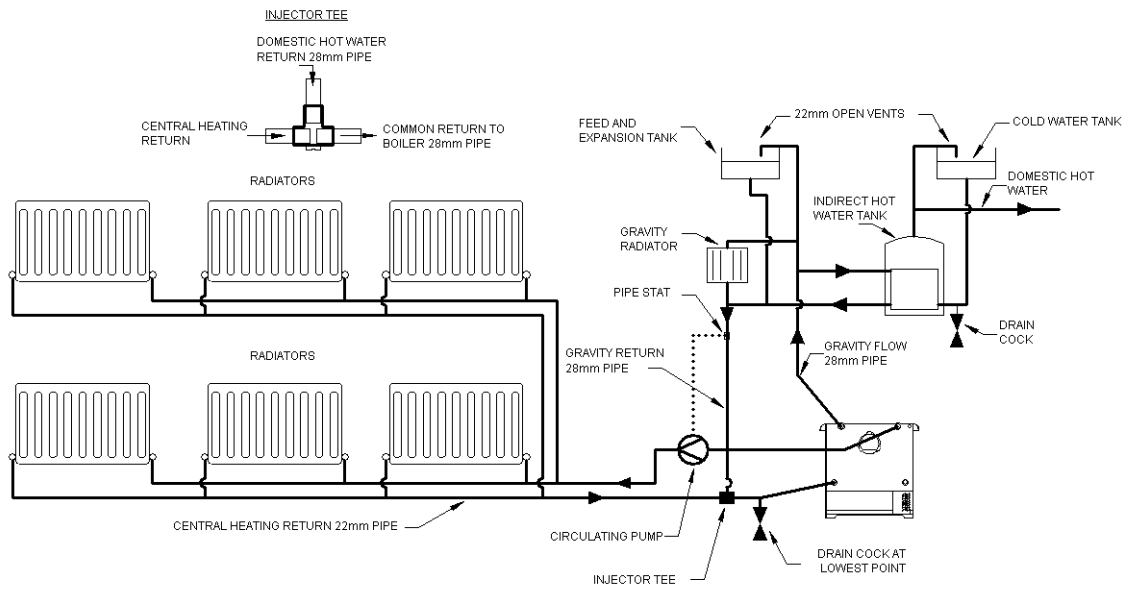

FIG. 14. Central heating and domestic hot water system using three boiler tappings.

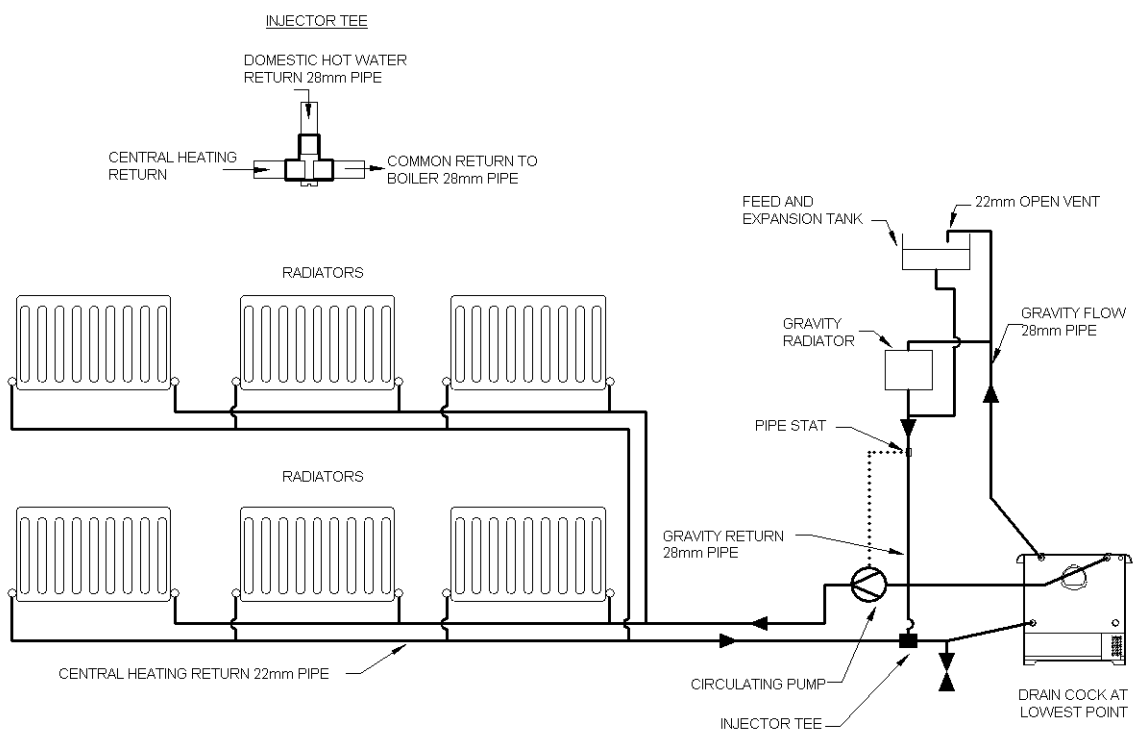

FIG. 15. Central heating without domestic hot water system using three boiler tappings.

STRATFORD

CENTRAL HEATING BOILER STOVES

Stratford is a brand name of Arada

All Stratford ECOBOILER Cassette stoves are manufactured in the UK



Arada Ltd

Weycroft Avenue - Axminster - Devon
EX13 5HU
United Kingdom

www.aradastoves.com

T: +44 (0)1297 35700

info@aradastoves.com