



STRATFORD

For stove ranges:

Stratford Ecoboilers

PLEASE RETAIN THIS GUIDE FOR FUTURE REFERENCE

BK560 Rev03

EN 13240:2001+

Amd. A2



August 2013

STRATFORD

More than 20 years experience has been put into the development of our stoves to ensure ultimate performance and years of trouble free use and enjoyment.

Every detail of the stove has been carefully designed and engineered which is why we are so confident in the reliability of our products.

Should you have any questions about our stoves that are not covered by this manual, please contact the Arada retailer in your area, or call our technical support department on

08448 567181 .

All Arada stoves are tested to European Standard EN 13240.

WARNINGS

Pure Petroleum coke or Bituminous house coal must not be burned in this appliance. The use of these fuels will invalidate the appliance guarantee.

Arada recommends the use of HETAS approved smokeless fuels which have been deemed suitable for use on closed appliances, including multi fuel stoves.

If in doubt, contact The Solid Fuel Association, telephone: 0845 601 4406 / 01773 835400 or visit www.solidfuel.co.uk

It is a legal requirement that the installation of all new or replacement, wood or solid fuel heating appliances must obtain building control approval from your local authority. This can be done by using a qualified heating engineer, affiliated to a government approved competent persons scheme such as operated by HETAS.

If in doubt, contact HETAS limited, telephone: 0845 634 5626 or visit www.hetas.co.uk

A fireguard conforming to BS 8423:2002 should be used in the presence of children and old or infirm people. Do not use aerosol sprays or any other flammable materials near the appliance when in use.

Arada Ltd will not be responsible for any consequential or incidental loss or injury however caused. Arada has a policy of continuous product development and therefore we reserve the right to amend any product specification without prior notice.

OPERATING YOUR STOVE

Our boiler stoves are designed to be operated with the fire door(s) closed at all times, apart from refuelling (when alight) or cleaning (when cold).

Never leave the appliance unattended for an extended length of time with the door(s) open.

Visit our YouTube channel for our 'how-to' series of videos:

<http://www.youtube.com/aradastoves>

FUEL TYPES

WOOD

Any type of wood is suitable provided it is well seasoned and has a moisture content below 20%. This usually implies that the timber has been suitably stored to allow moisture to evaporate for at least nine months in the case of soft woods, and at least twenty four months in the case of hard wood. We recommend that for general burning wood should be split into logs of no more than 100mm (4") diameter.

WARNING: Wet wood must not be used as this will greatly contribute to the creation of tar and creosote which may, in extreme cases, run down the chimney in liquid form. This will seriously damage both the chimney and the appliance and increase the risk of a chimney fire.

Please Note: If you have sticky tar inside the appliance or chimney your wood is 'green' or too wet.

PAPER – Paper will burn successfully. Burn dry paper only or chimney damage will occur.

WARNING: NEVER BURN PLASTICS, HOUSEHOLD WASTE OR LIQUID FUELS IN YOUR STOVE.

SOLID FUEL

Arada recommends the use of HETAS approved smokeless fuels which have been deemed suitable for use on closed appliances, including multi fuel stoves. These include:

Homefire Ecoal

Homefire Ecoal Instant Light

Homefire

Homefire Ovals

Supertherm

Ancit

Phurnacite

Taybrite

Newflame

Maxibrite

Sunbrite

Pureheat

For additional advice on fuels, please refer to The Solid Fuel Association.

LIGHTING THE FIRE

Prior to lighting the stove for the first time, check with the installer that:

- Installation and all building work is complete. (Refer to the installation guide.)
- The chimney is sound, has been swept and is free from obstruction.
- Adequate provision for combustion air has been made.
- That Building Regulations and any local by-laws have been followed during installation. See separate installation guide.
- All firebed surrounds and FEDS are in place.
- That the chimney draw has been checked and is within specification. With the chimney warm, the draught should be between 1-2 mm water gauge or 0.1 to 0.2 mbar.
- Ensure that the system is full of water & vented.
- That precautions have been taken to prevent corrosion.

USER GUIDE

- A Carbon Monoxide detector is correctly installed in the same room as the appliance.

WARNING: An over drawing chimney can cause over firing, resulting in damage to the appliance.

Ensure that you have read and understood these instructions before lighting the fire.

Do not light the fire if it is suspected that any part of the system could be frozen.

Always wear suitable protective fire gloves when refuelling your stove, such as the Arada glove supplied with your stove.

PLEASE NOTE: We recommend that you light a small fire for the first few days of use to cure the paint and allow the castings to relax. It is normal to experience some odours whilst the paint cures. These are non-toxic and temporary.

When lighting a cold boiler appliance it is not uncommon for condensation to form when the hot air makes contact with the cold boiler jacket. This is only temporary and no fault of the appliance, once the boiler water temperature rises the condensation will stop.

Some models have holes in their bases to accommodate a heat shield. Condensation may pass through these during the initial lighting of the stove. Please ensure your hearth is protected from the possibility of being permeated/dicoloured by condensation.

AIR INLET CONTROLS

Your stove has three air inlet controls. These are located either on the stove body or the door.

The primary air inlet provides under draught to the base of the fire chamber , the airwash

system (secondary air) providing overdraught and the 'Easy Boost' provides an on demand increase in air for combustion.

PRIMARY AIR

The primary air is supplied through the thermostatically controlled air inlet beneath an access cover on left side of your stove. This should have been calibrated when the stove was installed. (See accompanying installation guide). It regulates the amount of under draught air entering the stove depending on the setting of the control knob.

The control knob is numbered 0 to 5 relating to the nominal temperature of the water within the boiler jacket.

With a correctly configured installation the water in the jacket should not exceed 80°C when the knob is set to 5.



If a lower radiator temperature is required a lower number should be selected. Some experimentation may be necessary to find the setting best suited to your requirements.

AIRWASH SYSTEM / SECONDARY AIR

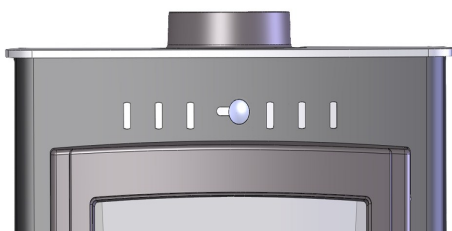

The airwash has an internal sliding plate with slots, housed in a cover plate, and is located above the fire door. Sliding the control knob to the **RIGHT** as far as it will go, achieves the fully open position.

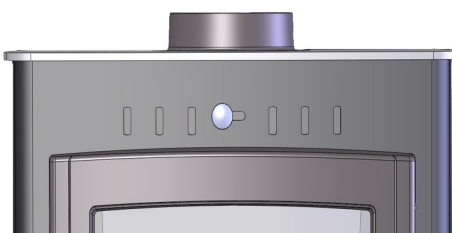

Sliding it to the **LEFT** will shut off the air inlet slots .

EASY BOOST

The easy boost air slider is positioned at the bottom of the door as pictured below.



Sliding the control towards the '+' symbol will increase the amount of under draught to the grate. Moving the control towards the '-' symbol reduces the under draught.

Using the easy boost slider allows a boost of air into the stove whilst lighting the fire and allows a rapid increase in boiler output if required for a period of time. It should be used for short periods only and will temporarily override the thermostatic control. Always close the easy boost slider if the stove is to be left unattended.

BURNING WOOD

- Set the fire by using scrunched up newspaper and place a layer of dry kindling wood on top of this.
- The use of two or three fire lighters may assist to light the kindling.
- Set the airwash and easy boost controls to the fully open position.
- Light the fire.
- After the kindling has caught light, you should leave the fire door ajar by about 20mm. This will aid flue draw.
- The flue draw should be established after five minutes, and the kindling reduced to form an ember bed.
- Carefully load the stove with well seasoned wood and close the fire door.
- After ten to fifteen minutes, regulate the airwash control, typically reduce to approximately half way.
- Close the easy boost air control.

BURNING SOLID FUELS

- Set the airwash to one quarter open.
- Set the easy boost air inlet to fully open.
- Light as with wood, with kindling and fire lighters.

USER GUIDE

- Once flue draw has been established, after about five minutes, carefully load the stove with fuel and close the door.
- When the fire is well alight close the easy boost slider and then regulate the burning rate by thermostat control.
- The airwash should be opened sufficiently to keep the door glass clean.

Whilst burning solid fuel it can be beneficial to occasionally riddle the grate bars so any burnt fuel will fall between the grate bars into the ash pan below. This will ensure a good under draught is maintained.

This is done by rotating back and fourth the riddling lever on the side of the stove. The

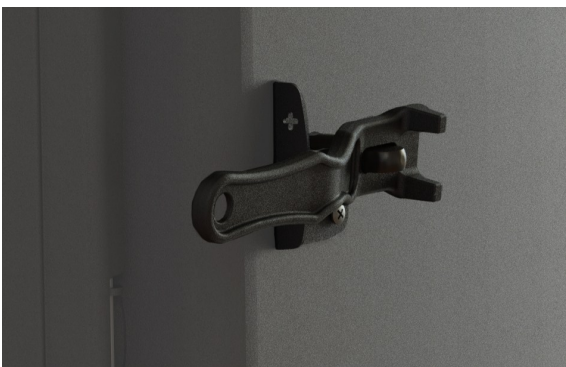

operating tool supplied with the stove should be used for this purpose.

WARNING: Properly installed, with a suitable flue or chimney, operated and maintained correctly, this appliance will not emit fumes into the dwelling.

Occasional fumes when de-ashing and refuelling may occur. However, persistent fume emission is potentially dangerous and must be investigated by a HETAS registered installer.

Stop using the appliance if you smell fumes or see smoke escaping.

If fume emission does persist, the following immediate actions should be taken:

- Open doors and windows to ventilate room.
- Let the fire die or extinguish and safely dispose of fuel from the appliance.
- Check for flue or chimney blockage, and clean if required.

Seek expert advice from your HETAS registered installer. Do not attempt to re-light the fire until the cause of the fume emission has been identified and corrected.

MULTI FUEL GRATE

The grate in your stove comprises of a series of reciprocating cast iron bars seated on a pivoted comb. These should come pre-assembled in your new stove.

All bars in the grate are identical, but every other bar is turned though 180 degrees, with the ends of the bars marked 'H' sitting on the high sections of the comb, and the ends marked 'L' sitting on the low sections.

The riddling lever, either on the side or front of the stove, can be operated with the stove operating tool to riddle ash into the ash pan below. Only riddle the stove with the door closed and stop once red embers begin to fall into the ash pan.

After extended use it may be necessary to replace some of the grate bars. Periodic inspection of the bars is recommended and any damaged bars replaced. Also check for obstructions that may prevent the operation of the riddling mechanism.

DOOR GLASS

The door glass should remain clear during normal burning. However, under certain conditions, such as burning at a low rate, using

damp wood or overnight burning, the glass may become somewhat blackened. To remedy this, operate the appliance at a fast rate. Alternatively when the stove is cold, open the door and clean the inside face of the glass with a damp cloth or with glass cleaner (available from stove stockists and online at www.aradastovesandspares.com).

REDUCED BURNING

When wood is burnt slowly in a closed appliance, it produces moisture and tar, which will create condensation and deposits in the chimney. This effect can be minimised by burning hard for a short period, fifteen to twenty minutes, twice a day. The easy boost air inlet can be used to achieve this faster burn rate. Remember to close the easy boost inlet afterwards as this overrides the stoves automatic thermostatic control.

Please Note: To avoid chimney problems your appliance should not be burnt at a reduced burn rate without a period of fast burning.

OVER FIRING & CHIMNEY FIRES

DO NOT over fire your appliance. Firing the stove at maximum for prolonged periods may result in over-firing. If the chimney connector or casing glows red the appliance is being over-fired this may result in a chimney fire.

ASH REMOVAL

The appliance will require ash to be removed periodically but an ash bed of approximately 20mm (3/4") should be maintained. Care must be taken not to burn hands or household objects with falling embers.

The ash pan should be emptied when the level of ash reaches the top of the ash pan. On no account should the ash be allowed to build up to touch the underside of the grate bars, as this will greatly reduce the life span of the grate. The ash will require less frequent removal when burning wood than solid fuels.

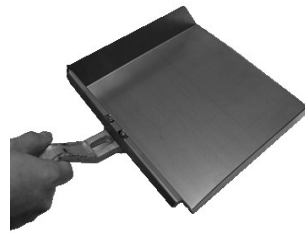

WARNING: The ash can be very hot. Empty only into a metal container. Even if the ash appears cold, red-hot embers may be concealed and could easily start a fire or cause an injury.

FEDS INSPECTION (WHERE FITTED)

The Flue Exhaust Diversion (FEDS) system needs to be checked regularly to ensure any build up of ash and other debris is removed. The Installation Guide contains details on how to remove and inspect the outer feds plate. This should be done only when the stove is unlit and cold.

THERMOSTAT MAINTANENCE

It is possible that over time, especially if ash is not removed regularly, the primary air inlet and its damper flap may become restricted / blocked by ash which may compromise the correct operation of the thermostat.

The installation guide contains details on how to maintain the operation of the damper flat and thermostat housing.

MAINTENANCE

SUMMER STORAGE / NON USAGE

Please ensure that your stove is left clean and moving components are well lubricated for the summer months (during periods of prolonged non-use). If possible store the FEDS plate outside of the stove. Check all moveable components at regular intervals, to ensure they are moving freely.

Allow air movement through the stove, by opening the airwash and primary air inlet control(s) to about half way, open or leave the door ajar. This will allow a free flow of air through the appliance thus preventing moisture and condensation forming inside the stove and chimney. This preventative maintenance will ensure your stove stays in the best condition for the coming winter months.

ADJUSTING THE DOOR HINGES

Once the appliance has been under fire for a period of time the fire door may appear to have moved out of alignment with relation to the door aperture or catch. This is quite normal and due to the settling of the casting.

The fire door can be re-aligned as follows:

1. When the appliance is cold, open the fire door so that it is at right angles to the front of the stove.
2. Lift the fire door up off its hinges.
3. Gently tap the hinge pins to compensate for the misalignment.
4. Re-fit the door and check to ensure it now sits square to the body; if not repeat the above steps.

If the fire door needs to be raised, please follow:

1. When the appliance is cold, open the fire door so that it is at right angles to the front of the stove.
2. Lift the fire door up off the hinges.
3. Drop one washer on the top and bottom hinge pins. Fit the door and check.

REPLACEMENT PARTS

As a leading manufacturer we are conscious of being able to support all our stove users with the supply of spare parts to ensure your continued enjoyment and warmth from your Arada stove. You can find a complete list of spares and consumables such as liners, grate bars and throat plates as well as items to enhance its visual appearance and efficiency such as Arada anthracite stove paint and rope kits.

All the above can be ordered from you local stove dealer or online direct from Arada at:

www.aradastovesandspares.com

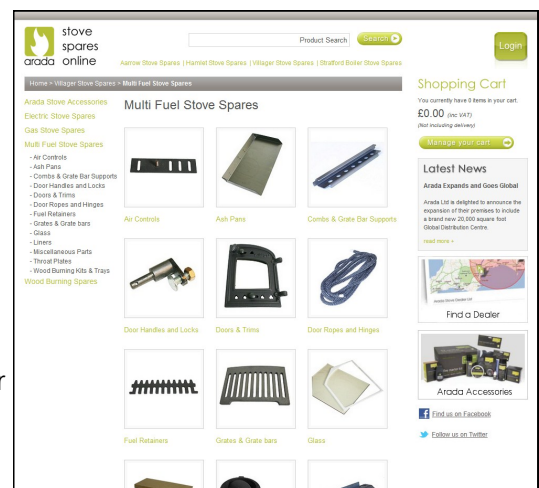

GUARANTEE

When you buy a STRATFORD Boiler stove, you are not only buying a first class appliance you are buying a commitment from us to look after you and your appliance for as long as you want.

All Stratford Ecoboilers will have a one year guarantee as standard but this can be upgraded free of charge to a full five year guarantee by registering the stove purchase and installation on line at www.stratfordboilerstoves.co.uk within one month of installation. Part of the registration process will require details of where the stove was purchased and the installer details. Those stoves brought through official Stratford dealers and installed by a suitably qualified engineer will then be eligible for the three year warranty. Non registered stoves, and stoves not installed by HETAS engineers or not purchased from an approved Stratford dealer will only have a standard one year guarantee from the date of purchase. This guarantee applies to stoves fitted in the same country as its purchase. Stoves brought through the internet in the UK and then taken abroad will not be eligible for any guarantee.

All guarantees apply to the body of the fire, i.e. the steel carcass and items fixed immovably thereto.

Arada Ltd, cannot guarantee items which are susceptible to breakage or damage through careless handling, dropping etc., or through misuse of the appliance by over firing, burning petroleum coke, etc. Nor can the guarantee be extended to deterioration of parts through fair wear and tear. Firebox linings, grate bars, fuel retainer, FED (throat plate), gasket material and door glass are therefore not covered by the guarantee. The external paint finish and thermostat carry a one year guarantee only.

The guarantee is conditional upon the appliance being installed, serviced and checked annually by a qualified heating engineer, with documentation to be retained and produced in the event of a claim being made.

Claims are not valid where installation does not conform to appropriate building regulations.

THE USE OF SPARES OTHER THAN THOSE SUPPLIED BY ARADA LTD WILL INVALIDATE THE GUARANTEE.

If your appliance proves to be defective as a result of faulty materials or workmanship during the guarantee period, we will repair or replace it free of charge as long as the fire has been installed according to the manual instructions and the installation is signed by a suitably qualified engineer at the time of installation. All guarantee periods commence on the date of purchase and are non-transferable.

Our guarantee is offered as an addition to your statutory rights. For users without access to the internet please call 01297 35700 for further assistance.

If you think your fire is not working correctly or in the event of a breakdown, in the first instance contact your local retailer or installer for assistance.



Technical Information

1 kW = 3,420 BTU

Freestanding

Description	Product Code	Output to Room	Output to Water Wood	Output to Water Solid	Height	
		kW	kW	kW	mm	inches
Ecoboiler 9 High Efficiency	EB9HE-G2	1.5-4.5	6.75	8.86	570	22 ^{1/2}
Ecoboiler 12 High Efficiency	EB12HE-G2	2-6	9	12	603	23 ^{3/4}
Ecoboiler 16 High Efficiency	EB16HE-G2	2.5-8	13	16	659	26
Ecoboiler 20 High Efficiency	EB20HE-G2	3-10	16	20	659	26
Ecoboiler 25 High Efficiency	EB25HE-G2	3.5-12	20	25	725	28 ^{1/2}

Inset Models

Description	Product Code	Output to Room	Output to Water Wood	Output to Water Solid	Height	
		kW	kW	kW	mm	inches
Ecoboiler 9 High Efficiency Inset	EB9HE-INSET-G2	1-3	7	9.4	590	23 ^{1/4}
Ecoboiler 12 High Efficiency Inset	EB12HE-INSET-G2	1-6	9	12	590	23 ^{1/4}
Ecoboiler 16 High Efficiency Inset	EB16HE-INSET	2.5-8	13	16	635	25

Boiler Tapping Positions

Description	Product Code	A	B	C	D
Ecoboiler 9 High Efficiency	EB9HE-G2	260	288	255	356
Ecoboiler 12 High Efficiency	EB12HE-G2	326	324	252	422
Ecoboiler 16 High Efficiency	EB16HE-G2	384	361	270	481
Ecoboiler 20 High Efficiency	EB20HE-G2	340	362	268	457
Ecoboiler 25 High Efficiency	EB25HE-G2	390	416	280	544

Description	Product Code	F	G	H	I	K
Ecoboiler 9 High Efficiency Inset	EB9HE-INSET-G2	165	49	139	172	345
Ecoboiler 12 High Efficiency Inset	EB12HE-INSET-G2	165	49	139	172	345
Ecoboiler 16 High Efficiency Inset	EB16HE-INSET	177	59	120	168	355

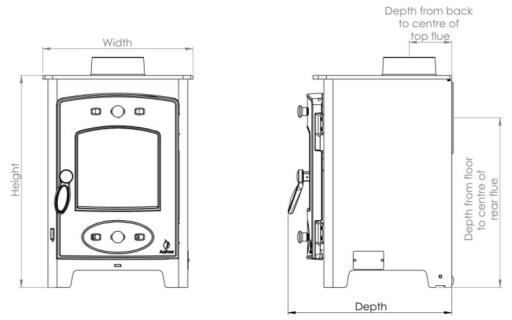

Width		Depth		Height to centre of rear flue		Depth from back to centre of top flue		Minimum distance to combustible materials (mm)		Flue Diameter		Nett Efficiency
mm	inches	mm	inches	mm	inches	mm	inches	Rear	Side	mm	inches	
466	18 ^{1/4}	417	16 ^{1/2}	431	17	144	5 ^{3/4}	140	120	101	4	71.1%
533	21	412	15 ^{3/4}	442	17 ^{1/2}	149	5 ^{3/4}	150	130	127	5	71.5%
590	23 ^{1/4}	402	17 ^{1/2}	501	19 ^{3/4}	147	5 ^{3/4}	250	240	127	5	72.8%
590	23 ^{1/4}	443	19 ^{1/2}	498	19 ^{1/2}	152	6	180	160	152	6	72.8%
678	26 ^{3/4}	498	19 ^{1/2}	565	22 ^{1/4}	152	6	195	180	152	6	71.6%

Width		Depth		Depth into fireplace		Depth of front fascia		Flue Outlet	Nett Efficiency
mm	inches	mm	inches	mm	inches	mm	inches		
548	21 ^{1/2}	578	22 ^{3/4}	353	14	179	7		73.1%
548	21 ^{1/2}	578	22 ^{3/4}	353	14	179	7		72.7%
625	24 ^{1/2}	586	23	357	14	179	7		73.2%

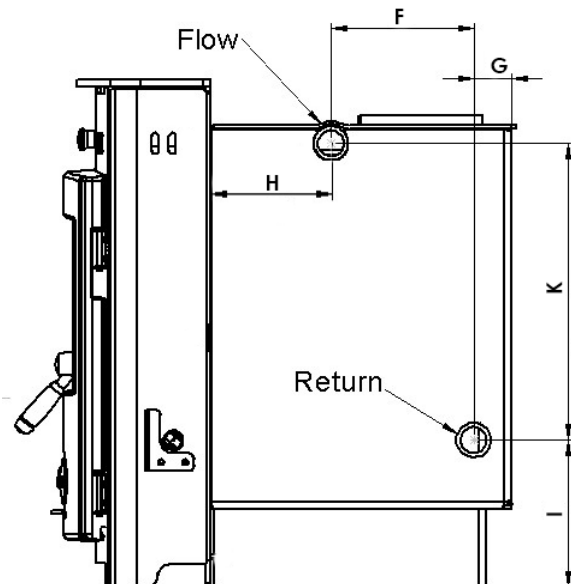
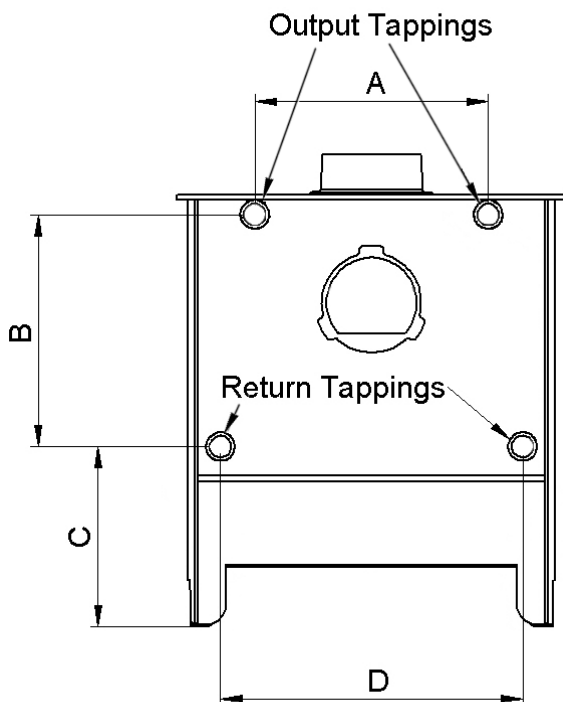

Final Factory Check list

Quality / Finish	
Flue Outlet	
Hot Plate	
Fuel Retainer	
Firebox Liners	
Throat Plate	
Door Catch / Door Handle	
Operating Tool	
Stove Glove	
Grate / Fuel Bed	
Installation Guide	

Model:

Assembled By.....

Checked by.....

We recommend recording where and when you purchased your stove for future reference:
--



The Fireworks
Weycroft Avenue
Axminster
Devon
EX13 5HU
www.arada.uk.com
www.aradastovesandspares.com